

MATERIAL

Thermoplast (Polyamid PA), schwarz, matt.

STANDARDAUSFÜHRUNGEN

- **GN 6336.3:** buchse Stahl verzinkt, Durchloch, schräg.
- **GN 6336.3-NI:** Nabe Edelstahl AISI 303 mit schräger Durchloch-Bohrung, nur teilweise Gewinde.

ANWENDUNGEN

Schnellspan-Sterngriffe GN 6336.3 werden eingesetzt, wenn schnelles Anziehen mit geringer Spannkraft erforderlich ist.

MONTAGEHINWEISE

Der Griff wird schräg auf den Gewindebolzen aufgesteckt. Beim Spannen rastet die Mutter in die Gewindegänge des Bolzens ein. Mit einer geringfügigen Drehung kann jetzt gespannt werden.

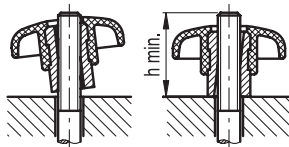

Anwendungsbeispiele
Der Gewindebolzen muss
länger als "h" sein

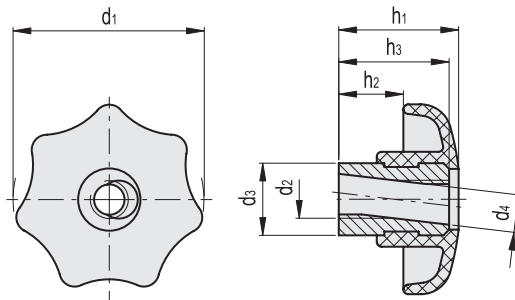

GN 6336.3

Code	Artikelnummer	d1	d2	d3	d4	h1	h2	h3 min	⚖️
GN.29211	GN 6336.3-40-M8	40	M8	16	8.4	26	13	24	32
GN.29221	GN 6336.3-50-M10	50	M10	20	10.5	34	17	30	60
GN.29231	GN 6336.3-63-M12	63	M12	26	13	42	21	37	129

GN 6336.3-NI

INOX
STAINLESS
STEEL

Code	Artikelnummer	d1	d2	d3	d4	h1	h2	h3 min	⚖️
GN.29213	GN 6336.3-40-M8-NI	40	M8	16	8.4	26	13	24	32
GN.29223	GN 6336.3-50-M10-NI	50	M10	20	10.5	34	17	30	60
GN.29233	GN 6336.3-63-M12-NI	63	M12	26	13	42	21	37	129

